



## Efficiency Within Easy Reach







## The FAMA round shelf is the ideal complement to the market-leading FAMA pharmacy drawer.

For medicine packages which are frequently dispensed, the FAMA round shelf provides direct access with short distances. Using a combination of the FAMA full-height bays (for slow movers) and the FAMA round shelf (for fast movers) saves both time and space with a comparable investment volume since, overall, fewer drawer bays are required and access to the fast moving packages is much quicker.

### Advantages:

- Direct access from the point of sale to fast moving medication
- Very good visibility ensures that packages are quickly located
- Product filling and removal can take place simultaneously from both sides
- Simple and easy refilling thanks to patented magnetic mechanism
- Observance of the FIFO principle\* thanks to filling from the back

\* FIFO = first in - first out



Simple operation through rotatable shelves



Quick removal of packages



Easy refilling thanks to magnetic storage segments



Observance of the FIFO principle thanks to filling from the back

## Round shelf 1200

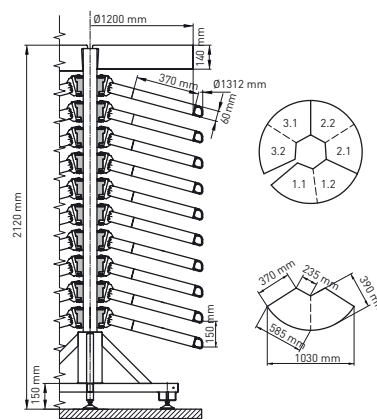

<b>Diameter:</b>	1200 mm (storage segments 1312 mm)
<b>Height:</b>	2120 mm
<b>Footprint (base):</b>	1.4 m <sup>2</sup>
<b>Storage area:</b>	6 m <sup>2</sup>
<b>Capacity:</b>	Up to 400 articles (channels) with up to 3,400 packages
<b>Number of shelves:</b>	10
<b>Depth of shelves:</b>	370 mm

## Round shelf 1800

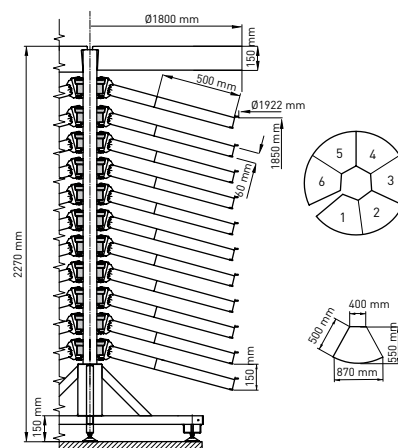

<b>Diameter:</b>	1800 mm (storage segments 1922 mm)
<b>Height:</b>	2270 mm
<b>Footprint (base):</b>	2.9 m <sup>2</sup>
<b>Storage area:</b>	13 m <sup>2</sup>
<b>Capacity:</b>	Up to 700 articles (channels) with up to 8,000 packages
<b>Number of shelves:</b>	11
<b>Depth of shelves:</b>	500 mm

# Willach Pharmacy Solutions.

## The right prescription for every pharmacy.

Willach is the market leader in Europe with regard to professional storage and dispensing equipment for medicines. With FAMA and CONSIS, Willach can provide system solutions for the conventional and fully automated storage of medicine packages: for any type of pharmacy, for any size of pharmacy. Willach undertakes all product development and production in Germany to assure the highest quality standards.



### CONSIS robotic dispensers

Consis robotic dispensers offer a tailor-made and highly efficient automation concept for your pharmacy. Whether you want to save time or gain space: Consis has the right solution for every situation.



### FAMA drawer systems

Fama large-capacity and underbench drawers provide fast access to packages, with good visibility, excellent space utilisation and ergonomically perfect operation. No other system offers you drawers which can store more packages in the same space.



### FAMA shelving systems

Fama worktop and fast mover shelves were developed as a modular system to achieve the greatest possible flexibility. They can be precisely adapted to your individual requirements. Fama round shelves store fast moving items to provide direct access and can be flexibly configured.



#### UK Sales Office:

Willach Pharmacy Solutions  
Concorde House  
Trinity Park, Solihull  
Birmingham B37 7UQ  
United Kingdom  
Phone +44 (0) 1216 355 025  
info.uk@willach.com  
www.willach.com

#### German Head Office:

Willach Pharmacy Solutions GmbH  
Stein 2  
53809 Ruppichterath  
Germany  
Phone +49 (0) 2295 9208 0  
Fax +49 (0) 2295 9208 499  
info@willach.com  
www.willach.com

Willach Group